

SICHERHEITSLEUCHE IP65 60250

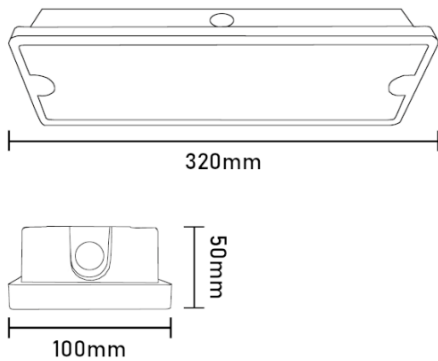

Technische Daten

Artikelnummer	60250
Netzspannung	220-240V
Frequenz	50-60Hz
Leistung (W)	8W
Akkumulator	Li-Ion 3.7V 2.0Ah
CCT	5000K
CRI	85
Luminance	400cd/m ²
Schutzklasse	II
Abmessung	320 x 100 x 50

Betrieb	L' , L, PE, N
Testsystem	Automatischer Selbsttest
Notlichtdauer	3h
Montage	Deckenmontage
Gehäusematerial	Polycarbonat
Gehäusefarbe	Weiss
Leuchtmittel	LED
Schutzart	IP65
Umgebungstemperatur	0-40 Grad celsius
Gewicht	0.450 kg